

DelVal[®] SERIES 46 /49

**Double Eccentric High Performance Butterfly Valves
Double Flanged**

Sizes 3" - 24" / DN 80 - DN 600

ASME Class 150 & Class 300



Leading the Industry with Innovation by Design

DelTech Controls is pleased to offer top-of-the-line products in pipeline flow control. The DelVal Series 46/49 Double Eccentric High Performance Butterfly Valve has been developed with extensive application, design and manufacturing expertise. These products are produced by employing modern manufacturing practices under a robust quality assurance system. These practices ensure consistent product quality and dependable performance. The DelVal Series 46/49 has been designed to include state-of-the-art features that are described in this bulletin.

Features

01. Top Flange

The top flange is drilled as per EN ISO 5211 to accommodate direct mounting of a wide range of actuators.

02. Body

Double flanged raised face, serrated finish body, drilled to meet ANSI & various international standards. Bidirectional sealing as standard in conformance with full ASME class 150 and class 300 rating.

03. Pin

Pins are offset from the center of the stem which places them in compression rather than shear thus eliminating potential for failure. The pins are precision fit and wedge types which provide positive mechanical attachment of disc to stem.

04. Disc Stop

The disc stop is a machined position stop on the body that locates the disc in the seat to achieve maximum seat and seal life. The disc stop is designed to prevent disc from rotating in to the wrong direction and minimizing possible seat damage.

05. Seat Retainer

Retains seat in the body and is supplied in the same material as the body.

06. Stem Seal

Stem assembly is "live loaded" with two Bellville Spring Washers. This ensures continuous compression of packing and sealing contact at the stem and body. Rocker shaped gland bridge compensates for uneven adjustment of gland bolts.

07. Blow-out proof stem

Retainer circlip provides blow -out proof stem.

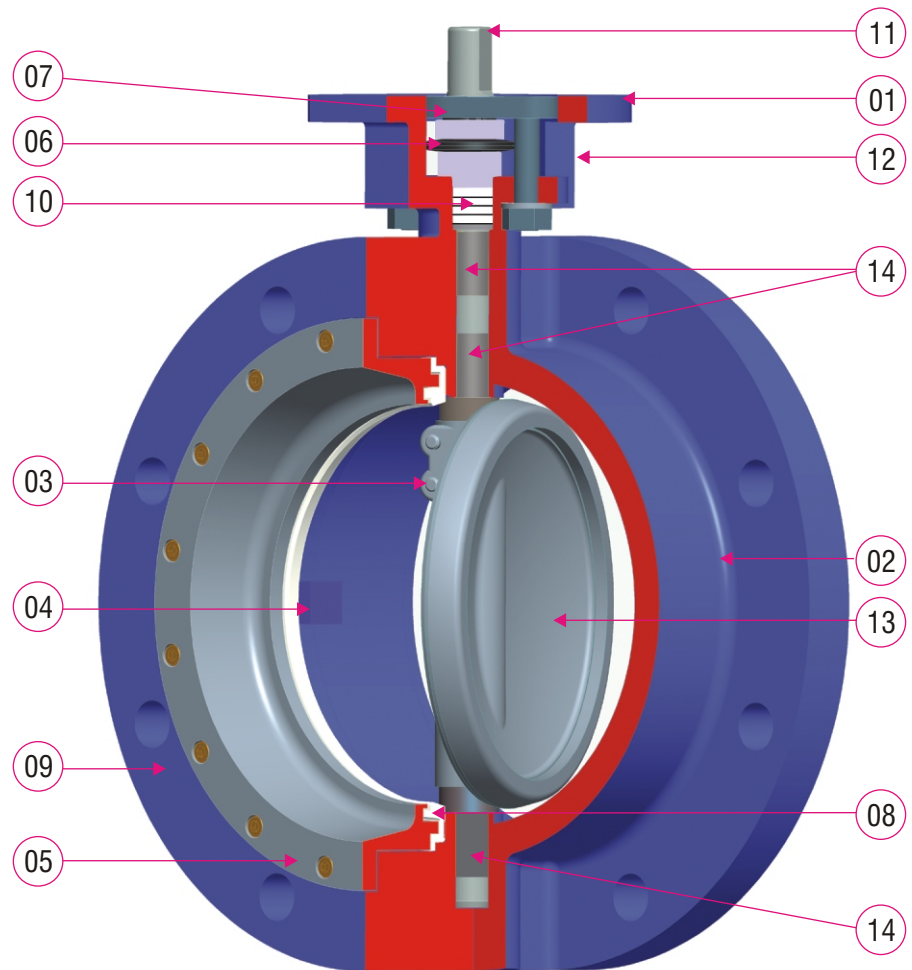

08. Seat

The unique seat design utilizes a flexible lip seal concept. When the disc closes, this action causes a slight deflection in the seat, energizing the seat. During this energized position, the seat has a stored energy force constantly pushing against the disc. In addition to this "energized" force, when pressure is on the insert side, the pressure pushes under the lip which further amplifies the sealing force between the disc and the seat.

09. Bi-Directional Dead End Service

All valves are suitable for dead-end service to pull ANSI pressure rating, bi-directionally.

10. Adjustable Stem Packing

The stem packing system features a pull down gland with easy access to the adjusting hex head nuts without removal of the actuator.

11. Stem

The high -strength stem is SS 316 or 17-4 ph stainless steel that provides maximum strength for high torque applications.

12. Extended Neck

Extended neck allows for 2" of pipeline insulation and easy access to stem packing adjustment and actuator mounting.

13. Disc

The disc has been engineered to maximize flow and minimize resistance to provide a high flow coefficient (Cv). The standard disc material is 316 stainless steel.

14. Bearings

Top and bottom bearings, consisting of a 316 stainless steel /TFE glass fabric liner bearing surface, securely support the stem.

Engineering

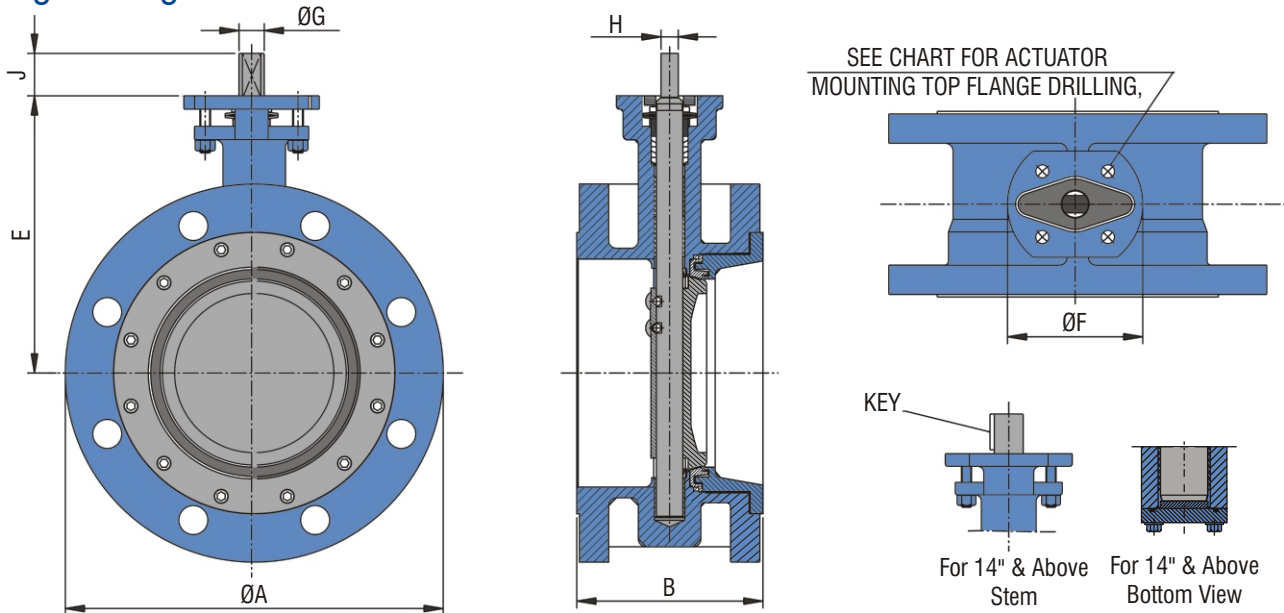

DIMENSIONS (mm)

Valve Size		ØA	✱B	E	ØF	TOP FLANGE DRILLING			ØG	H	J	Key Size	Weights In Kg.
Inches	DN					BC	NO. OF HOLES	HOLE DIA.					
3	80	190	114	151	102	70	4	10	16	11	32	-	24
4	100	230	127	172	102	70	4	10	16	11	32	-	35
5	125	255	140	188	125	70/102	4	10/12	19	13	32	-	40
6	150	280	140	209	125	70/102	4	10/12	19	13	32	-	48
8	200	345	152	239	152	125	4	14	22	16	32	-	56
10	250	405	165	280	152	125	4	14	30	22	51	-	70
12	300	485	178	310	152	125	4	14	35	24	51	-	115
14	350	535	190	335	210	125/165	4	14/21	40	-	51	12 x 8	135
16	400	595	216	407	210	165	4	21	50	-	64	12 x 10	165
18	450	635	222	427	210	165	4	21	55	-	64	16 x 10	235
20	500	700	229	450	210	165	4	21	60	-	102	18 x 11	340
24	600	815	267	530	300	254	8	18	70	-	102	20 x 12	485

TORQUE (Nm)

Differential Pressure				
PN3.5	PN7	PN10	PN16	Class150
32	33	34	37	40
43	46	49	53	68
59	65	70	78	83
88	95	104	116	124
148	162	175	199	214
193	219	244	283	315
235	285	336	413	465
389	482	579	735	836
496	618	744	936	1076
646	808	966	1224	1409
861	1087	1296	1663	1897
1305	1648	2008	2558	2958

ASME CLASS 150 (Series 46)

Valve Size		ØA	✱B	E	ØF	TOP FLANGE DRILLING			ØG	H	J	Key Size	Weights In Kg.
Inches	DN					BC	NO. OF HOLES	HOLE DIA.					
3	80	210	114	151	102	70	4	10	16	11	32	-	34
4	100	255	127	172	102	70	4	10	16	11	32	-	49
5	125	280	140	193	125	70/102	4	10/12	19	13	32	-	56
6	150	320	140	220	125	125	4	14	22	16	32	-	67
8	200	380	152	265	152	125	4	14	30	22	51	-	78
10	250	445	165	300	152	125	4	14	35	24	51	-	98
12	300	520	178	350	210	125/165	4	14/21	40	29	51	-	161
14	350	585	190	375	210	165	4	21	55	-	64	16 x 10	189
16	400	650	216	425	210	165	4	21	55	-	64	16 x 10	231
18	450	710	222	475	300	254	8	18	70	-	102	20 x 12	330
20	500	775	229	505	300	254	8	18	88.9	-	134	22.23x15.88	475
24	600	915	267	580	350	298	8	21	101.6	-	134	25.4x19.05	675

Differential Pressure				
PN10	Class 150	PN25	PN40	Class 300
34	40	44	54	60
49	68	74	95	108
88	111	123	161	186
120	154	175	234	275
228	300	341	459	545
338	461	529	731	876
473	639	729	1002	1189
724	1057	1257	1807	2194
879	1270	1492	2181	2645
1135	1651	1935	2785	3371
1500	2191	2605	3760	4589
2046	2979	3485	5100	6157

ASME CLASS 300 (Series 49)

* Face to Face dimension "B", generally conforming to API 609 Category B Double Flange (Short Pattern)/ISO 5752 Series 13/IS 13095 Short/BS EN 558 Series 13.

All bolt holes 1 1/8" and larger have an 8-UN thread series as per API 609 / MSS SP 68.

Above torque values for soft seat and indicative for flow in preferred direction i.e. seat retainer upstream, torque values for flow in non preferred direction i.e. seat retainer downstream, multiply the above values by 1.25. For other seat materials consult factory.

ASME CLASS 150 (Series 46)

Disc Position (Degrees)	Valve Size											
	3"	4"	5"	6"	8"	10"	12"	14"	16"	18"	20"	24"
10	4.1	8.4	13	26	48	76	114	133	181	171	204	278
20	14	29	42	74	145	231	340	421	556	592	734	1090
30	32	63	89	147	285	471	689	862	1125	1388	1731	2570
40	57	115	163	248	488	793	1150	1448	1880	3047	3149	4586
50	87	173	285	375	735	1193	1734	2186	2891	3926	4872	7265
60	124	249	376	559	1098	1782	2595	3246	4283	5685	7045	10560
70	163	327	618	789	1587	2534	3689	4599	6072	7755	8575	14275
80	200	401	684	1070	2116	3431	5010	6315	8353	10185	12750	19050
90	207	413	752	1227	2432	3909	5744	7254	9544	10950	13960	21025

ASME CLASS 300 (Series 49)

Disc Position (Degrees)	Valve Size											
	3"	4"	5"	6"	8"	10"	12"	14"	16"	18"	20"	24"
10	4.1	8.4	13	20	37	53	77	91	145	117	134	211
20	14	29	42	70	115	167	237	283	428	498	580	898
30	32	63	89	139	248	361	510	625	873	1188	1360	2127
40	57	115	163	245	432	639	887	1099	1494	2151	2488	3879
50	87	173	285	374	661	968	1351	1632	2298	3313	3855	6019
60	124	249	376	528	976	1437	2005	2378	3479	4809	5588	8713
70	163	327	618	727	1363	2011	2832	3336	4994	6554	7588	11738
80	200	401	684	934	1770	2646	3809	4465	7195	8825	9860	15600
90	207	413	752	1021	1956	2922	4214	4901	8022	9606	10829	17103

Cv Values

Rated Cv = The volume of water in USgpm that will pass through a given valve at a pressure drop of 1 Psi.

Feature and Selection

Double Offset Disc Design

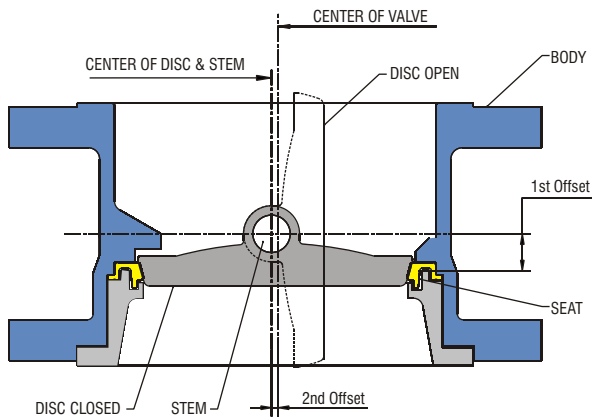

The offset disc produces a cam-like action, pulling the disc from the seat. This action reduces seat wear and eliminates seat deformation when the disc is in the open position. The disc does not contact the seat when the valve is in the open condition; therefore, seat service life is extended and torques are reduced. As the valve closes, the cam-like action converts the rotary motion of the disc to a linear type motion effectively pushing the disc onto the seat.

Seat Designs

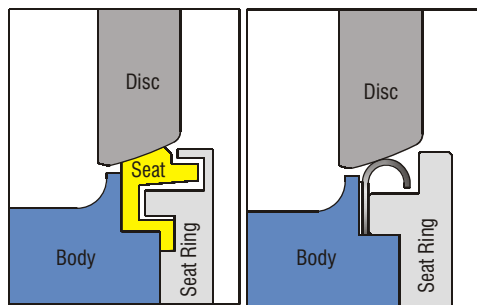

1. Teflon Seat

2. Metal Seat

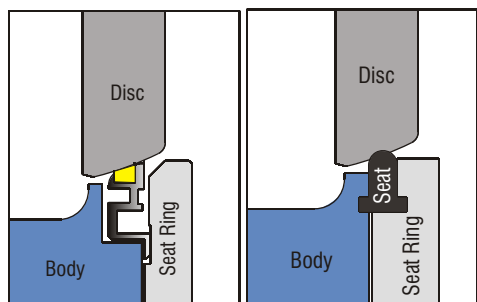

3. Fire Safe Seat

4. Elastomer Seat

1. **Teflon Seat** : Flexible lip seat design retains its original shape and maintain a seal against the disc regardless of the flow direction

2. **Metal Seat** : Flexible metal seat offers a very high sealing capability with low leakage rates. The mechanical properties and the shape of the metal seat allows it to flex and maintain constant positive sealing against the disc.

3. **Fire Safe Seat** : During and after fire, when the resilient material has been partially or completely destroyed, the metal seat ring provides a positive seal by remaining in constant contact with the disc in either direction of media flow.

4. **Elastomer Seat** : The heavy 'T' section seal ring is designed to eliminate the potential extrusion due to high shut-off delta P or high velocity.

Seat Pressure / Temperature

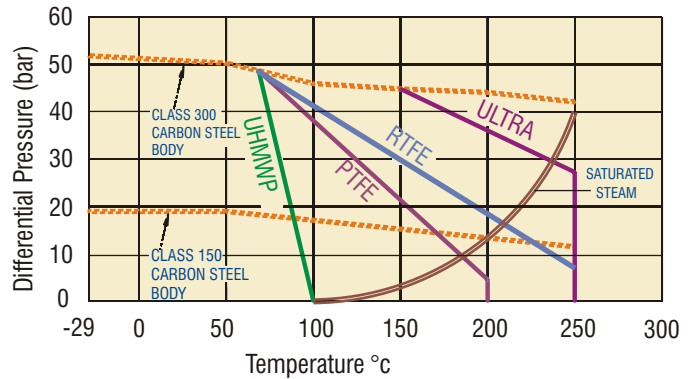

Special Applications

ULTRA seat

An engineered fluorocarbon polymer that is rated for 260°C. Excellent for handling aggressive fluids at high pressures. Ultra is recommended for extended service in hostile environments involving chemical, thermal, and mechanical stress. Ultra has excellent thermal stability and is ideal for steam, hot gases, and a variety of process chemicals where service can also be subject to pressure cycling.

NACE service

All valves conform to NACE MRO 103 standard. These valves are well suited for oil and gas industry applications requiring resistant materials to sulfide stress cracking.

Steam

Valves are available for saturated steam at 14 bar rating for series 46 and 31 bar for series 49.

Vacuum

Standard valves are rated for tight shut-off of vacuum to 2×10^{-2} torr.

Oxygen

Valves for critical gaseous oxygen service are specially prepared, cleaned, inspected, assembled and tested to ensure removal of all burrs, sharp edges, dirt, hydrocarbon oil or grease and other contaminants.

CODES AND STANDARDS

General design and manufacturing :- API 609 Category B/MSS-SP-68/EN 593

Inspection and Testing :- API 598 / MSS-SP-68 / EN 12266-1 / AISI/FCI 70-2

Fire safe testing :- API 607 / ISO 10497 / EN 12266-2

Pressure temperature rating :- ASME B 16.34 / BS EN 12516-1

Materials of Construction

- ◆ **Body** - D.I. ASTM A536 65-45-12 / Carbon Steel,
ASTM A 216 WCB / ASTM A352 LCB
Stainless Steel, ASTM A 351 CF8M / CF8
- ◆ **Stem Packing** - PTFE Chevron Packing - Standard Valve
Flexible Graphite Rings- Fire Safe & Metal Seat Valve
- ◆ **Stem** - ASTM A 479 SS316 (CLASS 150 up to 12")
ASTM A 564 17-4-PH Type 630 (CLASS 300/150)
ASTM A 479 SS410 (CLASS 150 / 300)

- ◆ **SEAT** - PTFE / RTFE / ULTRA /UHMWP
EPDM / BUNA / SILICONE/
VITON (PN 25 Max)
Fire Safe Seat
Metal Seat (SS316, INCONEL)
- ◆ **DISC** - Stainless Steel, ASTM A 351 CF8M / CF8

Other materials are available, please consult factory for specific application

Sr. No.	DESCRIPTION	
01	BODY	
02	DISC	
03	STEM	
04	SEAT	
05	SEAT RETAINER	
06	SOC. HD. CAP SCREW	
07	DISC SPACER	
08	BEARING	
09	DISC PIN	
10	STEM PACKING	
11	PACKING GLAND	
12	BELLVILLE WASHER	
13	GLAND FOLLOWER	
14	STEM RETAINER CIRCLIP	
15	GLAND FLANGE	
16	STUD	
17	HEX NUT	
18	THRUST BEARING	14" AND ABOVE
19	BOTTOM GASKET	
20	BOTTOM FLANGE	
21	HEX BOLT	

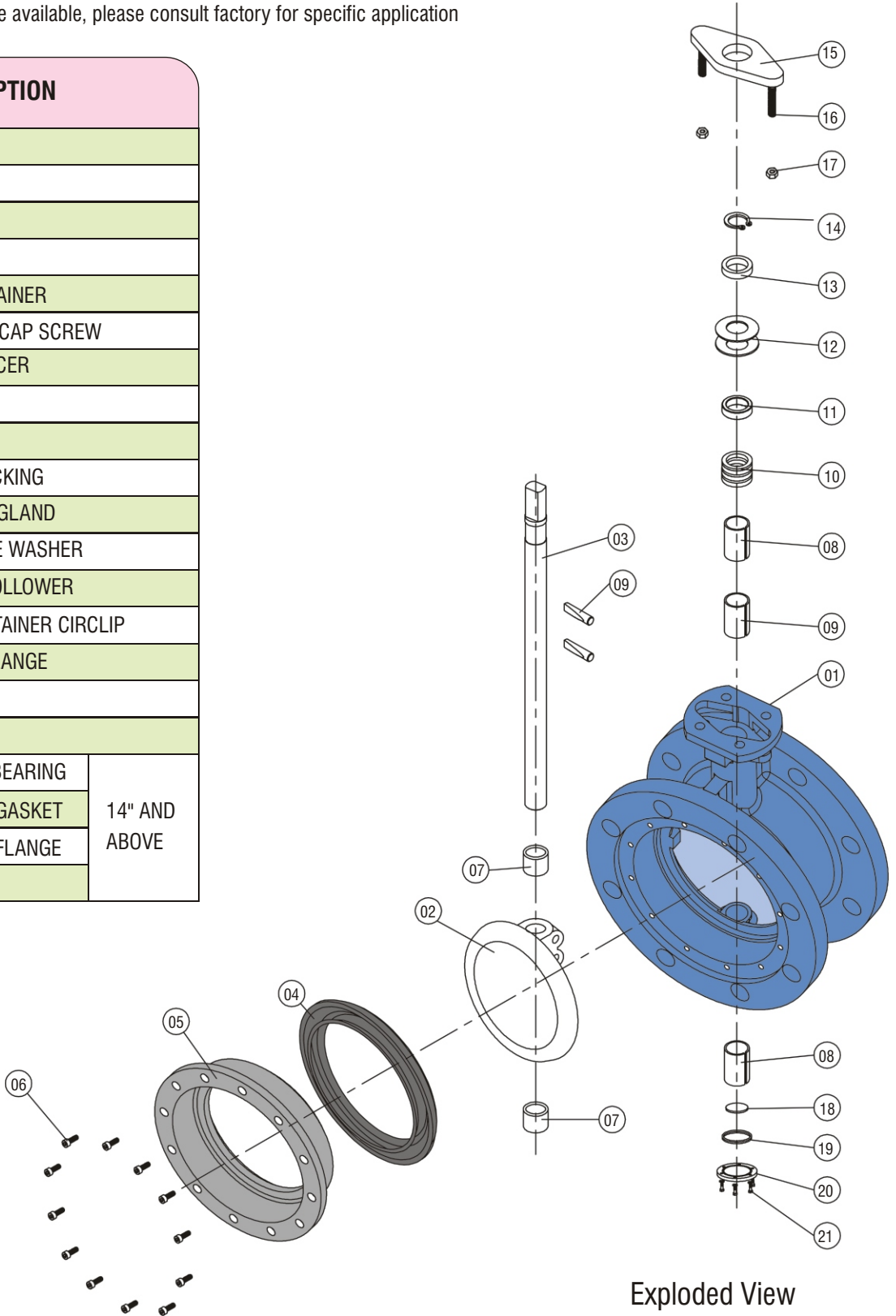

Exploded View

Operators



All valves can be direct mounted with pneumatic actuators or electric actuators and accessories for complete automation options such as fail open/close and positioner controlled. Valves can be mounted with manual overrides.



Valves up to size 24" can be direct mounted with gear operators for manual operation. Gear operators can also be attached with chain-wheel operators for opening or closing valves located on pipelines at high elevations.



Valves upto 6" for class 150 and upto 4" for class 300 can be supplied with lever handles for manual operation. Optional accessories for hand-lever operation can be provided for various flow control requirements. Pad locking can also be provided for preventing unauthorized operation.

How To Order Delval Valves

SERIES □ □		SIZE □ □ □		TRIM / OTHER VARIABLES / SPECIAL □ □ □ □ □				
VALVE DESCRIPTION	VALVE DESCRIPTION	BODY	DISC	STEM	SEAT	RATING	OPERATOR	SPECIAL
46 : Flange class 150 49 : Flange class 300	030 : 3" 040 : 4" 050 : 5" 060 : 6" 080 : 8" 100 : 10" 120 : 12"	2- D.I. 3- WCB 4- CF8M(SS316) 8- CF8(SS304)	4-CF8M(SS316) 8- CF8(SS304)	1- SS410 6- 17-4-PH 4-SS316	T-PTFE U-ULTRA G-UHMWP R-RTFE E-EPDM B-BUNA N S-SILICONE M-METAL (SS) N-METAL(INCONEL) F-FIRE SAFE	5 - Class 150 6 - Class 300	B-BARE L - LEVER G - GEAR	0-NO SPECIAL REQUIREMENT S - SPECIAL REQUIREMENT AS SPECIFIED BY CUSTOMER

For Example :- To order 300/12" , Flange body valve, Body-CF8M, Disc- CF8M, Stem-SS316, Seat-PTFE, Rating-Class 150, Gear operated, with no special requirements.

4 6 1 2 0 4 4 4 T 5 G 0

All statements, technical information and recommendations in the bulletin are for general use only. DelTech is not responsible for suitability or compatibility of these products in relation to system requirements. Consult DelTech distributors or factory for the specific requirements and material selection for your intended application. DelTech reserves the right to change or modify product design or product without prior notice. DelVal® - Registered trademark of DelTech Controls.

Distributor



DelTech Controls LLC

6068 Highway 73
Geismar, LA 70734
USA

Phone: (225) 744-4326
Fax: (225) 744-4328
Email : sales@deltechcontrols.com

DelVal Flow Controls Pvt. Ltd.

(A division of DelTech Controls LLC, USA)
Office & Works : Gat. No 625/1/2,
Kuruli, Tal. Khed, Pune-Nasik Highway,
Pune 410501, INDIA

Phone : +91-2135-662700
Fax: +91-2135-662727
Email : salesindia@deltechcontrols.com