

DelVal[®] SERIES 44/45, 47/48 & 4M/4N

Double Eccentric High Performance Butterfly Valves
Wafer and Lug

Sizes 2" - 48" / DN 50 -DN 1200

ASME Class150, Class 300 & Class 600



Leading the Industry with Innovation by Design

DelTech Controls is pleased to offer top-of-the-line products in pipeline flow control. The DelVal Series 44/45, 47/48, 4M/4N has been developed with extensive application, design and manufacturing expertise. These products are produced by employing modern manufacturing practices under a robust quality assurance system. These practices ensure consistent product quality and dependable performance. The DelVal Series 44/45, 47/48, 4M/4N has been designed to include state-of-the-art features that are described in this bulletin.

Features

Top Flange

The top flange is drilled as per EN ISO 5211 to accommodate direct mounting of a wide range of actuators.

Body

One-piece wafer body style or full lug style for dead end service. Both body styles offer bidirectional sealing as standard in conformance with full ASME class 150, class 300 and class 600 rating.

Pin

Pins are offset from the center of the stem which places them in compression rather than shear thus eliminating potential for failure. The pins are precision fit and wedge types which provide positive mechanical attachment of disc to stem.

Disc Stop

The disc stop is a machined position stop on the body that locates the disc in the seat to achieve maximum seat and seal life. The disc stop is designed to prevent disc from rotating in to the wrong direction and minimizing possible seat damage.

Seat Retainer

Retains seat in the body and is supplied in the same material as the body.

Stem Seal

Stem assembly is "live loaded" with two Bellville Spring Washers. This ensures continuous compression of packing and sealing contact at the stem and body. Rocker shaped gland bridge compensates for uneven adjustment of gland bolts.

Blow-out proof stem

Retainer circlip provides blow -out proof stem.

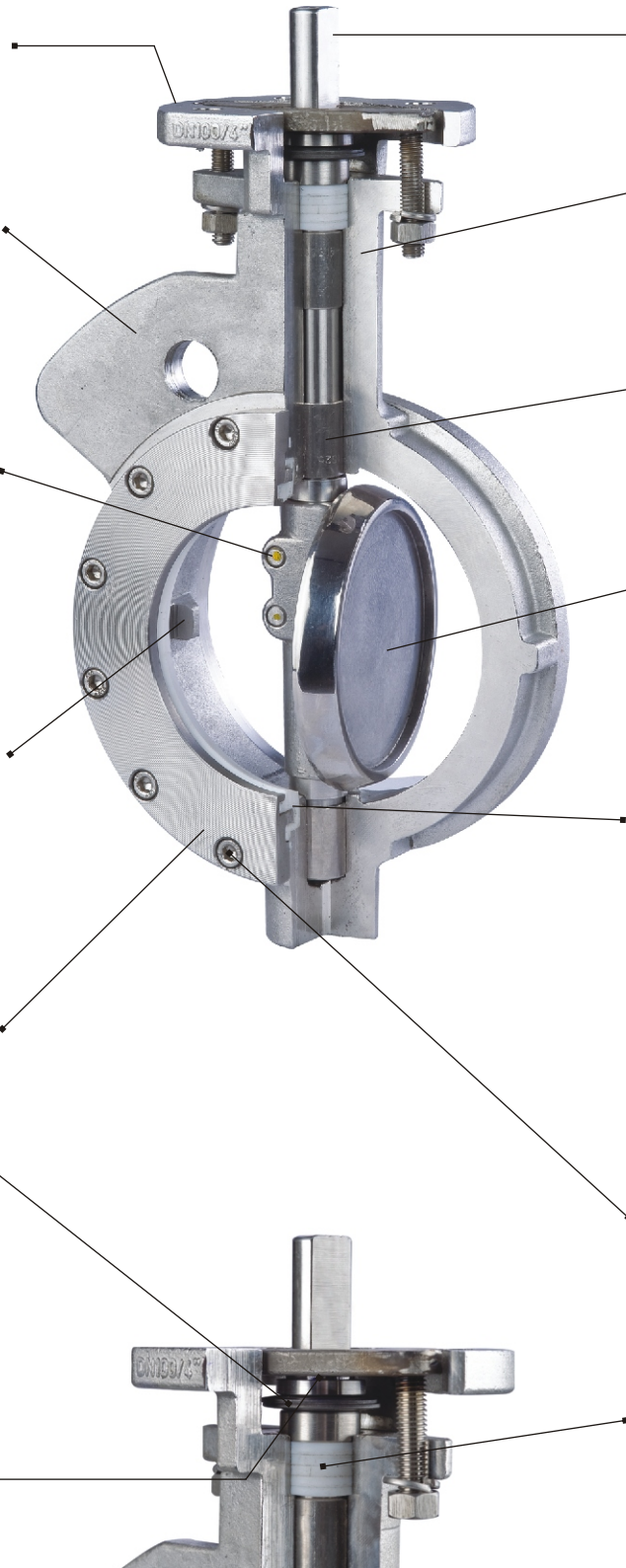

Stem

The high -strength stem is SS 316 or 17-4 ph stainless steel that provides maximum strength for high torque applications.

Extended Neck

Extended neck allows for 2" of pipeline insulation and easy access to stem packing adjustment and actuator mounting.

Bearings

Top and bottom bearings, consisting of a 316 stainless steel /TFE glass fabric liner bearing surface, securely support the stem.

Disc

The disc has been engineered to maximize flow and minimize resistance to provide a high flow coefficient (Cv). The standard disc material is 316 stainless steel.

Seat

The unique seat design utilizes a flexible lip seal concept. When the disc closes, this action causes a slight deflection in the seat, energizing the seat. During this energized position, the seat has a stored energy force constantly pushing against the disc. In addition to this "energized" force, when pressure is on the insert side, the pressure pushes under the lip which further amplifies the sealing force between the disc and the seat.

Bi-Directional Dead End Service

All lug valves are suitable for dead-end service to pull ANSI pressure rating, bi-directionally.

Adjustable Stem Packing

The stem packing system features a pull down gland with easy access to the adjusting hex head nuts without removal of the actuator.

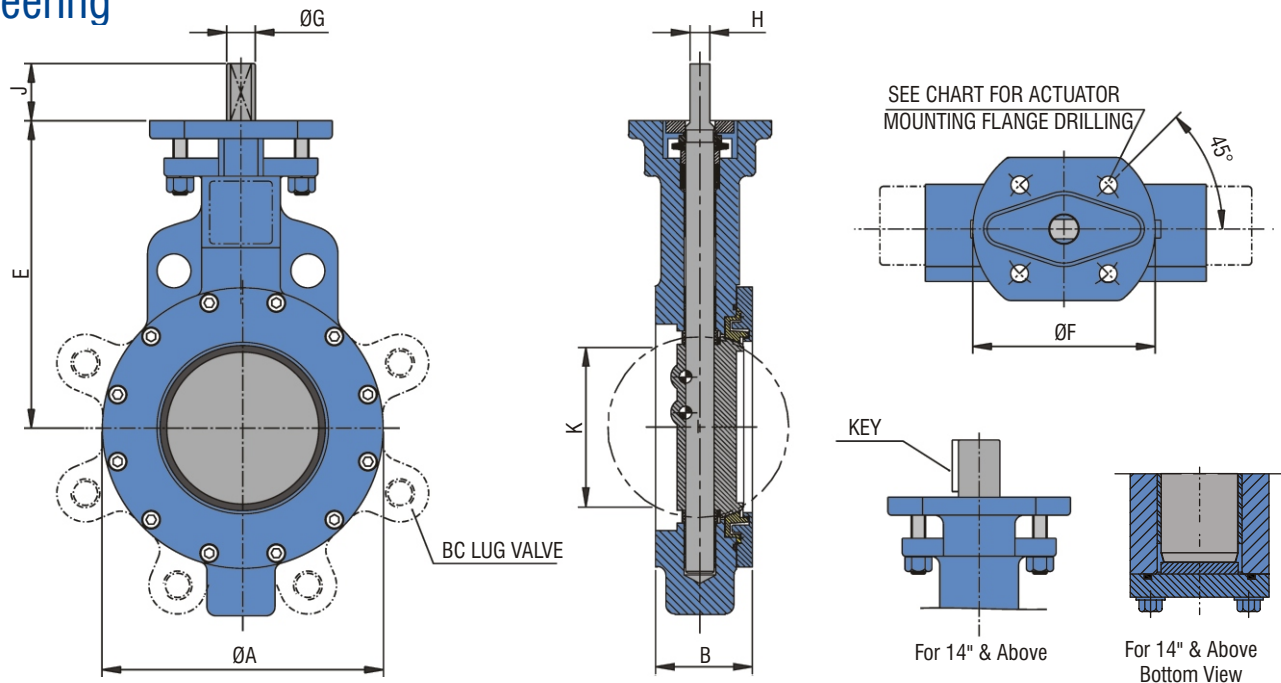

DIMENSIONS (mm)

Valve Size		ØA	*B	E	ØF	Top Flange Drilling			ØG	H	J	Key Size	K	Lug Bolting Data			Weights In Kg.	
Inch	DN					BC	No. of holes	Hole Dia.						BC	No. of holes	Threads UNC/UN-2B	Wafer	Lug
2	50	95	43	125	102	70	4	10	14	10	32	-	39.8	120.7	4	5/8-11	3.5	4.0
2 1/2	65	105	46	146	102	70	4	10	16	11	32	-	53.3	139.7	4	5/8-11	4.0	4.9
3	80	127	48	151	102	70	4	10	16	11	32	-	66.0	152.4	4	5/8-11	4.9	6.0
4	100	157	54	172	102	70	4	10	16	11	32	-	86.4	190.5	8	5/8-11	7.1	11.1
5	125	186	57	188	125	70/102	4	10/12	19	13	32	-	114.3	215.9	8	3/4-10	8.9	13.4
6	150	216	57	209	125	70/102	4	10/12	19	13	32	-	139.7	241.3	8	3/4-10	11.3	16.1
8	200	270	64	239	152	125	4	14	22	16	32	-	185.4	298.5	8	3/4-10	11.6	21.3
10	250	324	71	280	152	125	4	14	30	22	51	-	233.7	362.0	12	7/8-9	27.7	40.8
12	300	381	81	310	152	125	4	14	35	24	51	-	297.2	431.8	12	7/8-9	50.4	57.2
14	350	423	92	335	210	125/165	4	14/21	40	-	51	12 x 8	322.6	476.2	12	1-8	62.0	82.7
16	400	470	102	407	210	165	4	21	50	-	64	12 x 10	370.8	539.7	16	1-8	93.0	112.5
18	450	534	114	427	210	165	4	21	55	-	64	16 x 10	416.6	577.8	16	1 1/8-8	105.8	139.0
20	500	584	127	450	210	165	4	21	60	-	102	18 x 11	466.1	635.0	20	1 1/8-8	114.3	187.3
24	600	692	154	530	300	254	8	18	70	-	102	20 x 12	553.7	749.3	20	1 1/4-8	230	318.2
26	650	750	165	560	300	254	8	18	88.9	-	102	22.23x15.88	605.0	-	-	-	300	-
28	700	805	165	600	300	254	8	18	88.9	-	102	22.23x15.88	660.5	-	-	-	385	-
30	750	860	191	640	350	298	8	21	88.9	-	102	22.23x15.88	715.0	-	-	-	450	-
32	800	911	191	670	350	298	8	21	101.6	-	134	25.4 x 19.05	767.0	-	-	-	525	-
36	900	1028	203	705	350	298	8	21	101.6	-	134	25.4 x 19.05	864.2	-	-	-	775	-
40	1000	1125	217	810	415	356	8	33	120	-	150	32 x 18	945.0	-	-	-	1100	-
44	1100	1250	254	845	415	356	8	33	120	-	150	32 x 18	1040	-	-	-	1275	-
48	1200	1360	254	915	415	356	8	33	120	-	150	32 x 18	1125	-	-	-	1435	-

ASME CLASS 150 (Series 44/45)

Valve Size		ØA	*B	E	ØF	Top Flange Drilling			ØG	H	J	Key Size	K	Lug Bolting Data			Weights In Kg.	
Inch	DN					BC	No. of holes	Hole Dia.						BC	No. of holes	Threads UNC/UN-2B	Wafer	Lug
2	50	95	43	125	102	70	4	10	14	10	32	-	39.8	127.0	8	5/8-11	3.5	4.0
2 1/2	65	105	46	146	102	70	4	10	16	11	32	-	53.3	149.2	8	3/4-10	4.0	4.9
3	80	127	48	151	102	70	4	10	16	11	32	-	66.0	168.3	8	3/4-10	4.9	6.0
4	100	157	54	172	102	70	4	10	16	11	32	-	86.4	200.0	8	3/4-10	7.1	11.1
5	125	186	59	193	125	70/102	4	10/12	19	13	32	-	114.3	235.0	8	3/4-10	9.2	14.2
6	150	216	59	220	152	125	4	14	22	16	32	-	139.7	269.9	12	3/4-10	14.2	31.2
8	200	280	73	265	152	125	4	14	30	22	51	-	180.3	330.2	12	7/8-9	24.1	35.9
10	250	336	83	300	152	125	4	14	35	24	51	-	228.6	387.4	16	1-8	40.2	52.8
12	300	390	92	340	210	125/165	4	14/21	40	29	51	-	271.8	450.8	16	1 1/8-8	68.8	91.2
14	350	413	117	375	210	165	4	21	55	-	64	16 x 10	307.3	514.4	20	1 1/8-8	129.7	148.0
16	400	470	133	425	210	165	4	21	55	-	64	16 x 10	348.0	571.5	20	1 1/4-8	153.1	182.8
18	450	545	149	475	300	254	8	18	70	-	102	20 x 12	396.2	628.6	24	1 1/4-8	177.5	233.8
20	500	584	159	505	300	254	8	18	88.9	-	102	22.23x15.88	436.9	685.8	24	1 1/4-8	230.8	334.5
24	600	692	181	580	350	298	8	21	101.6	-	134	25.4x19.05	523.2	812.8	24	1 1/2-8	333.4	460.8

ASME CLASS 300 (Series 47/48)

* Face to Face dimension "B", generally conforming to MSS SP 68 TABLE 1 / API 609 Category B / BS EN 558-1 / ISO 5752 / ASME B 16.10

All bolt holes 1 1/8" and larger have an 8-Un thread series as per MSS SP 68 & API 609.

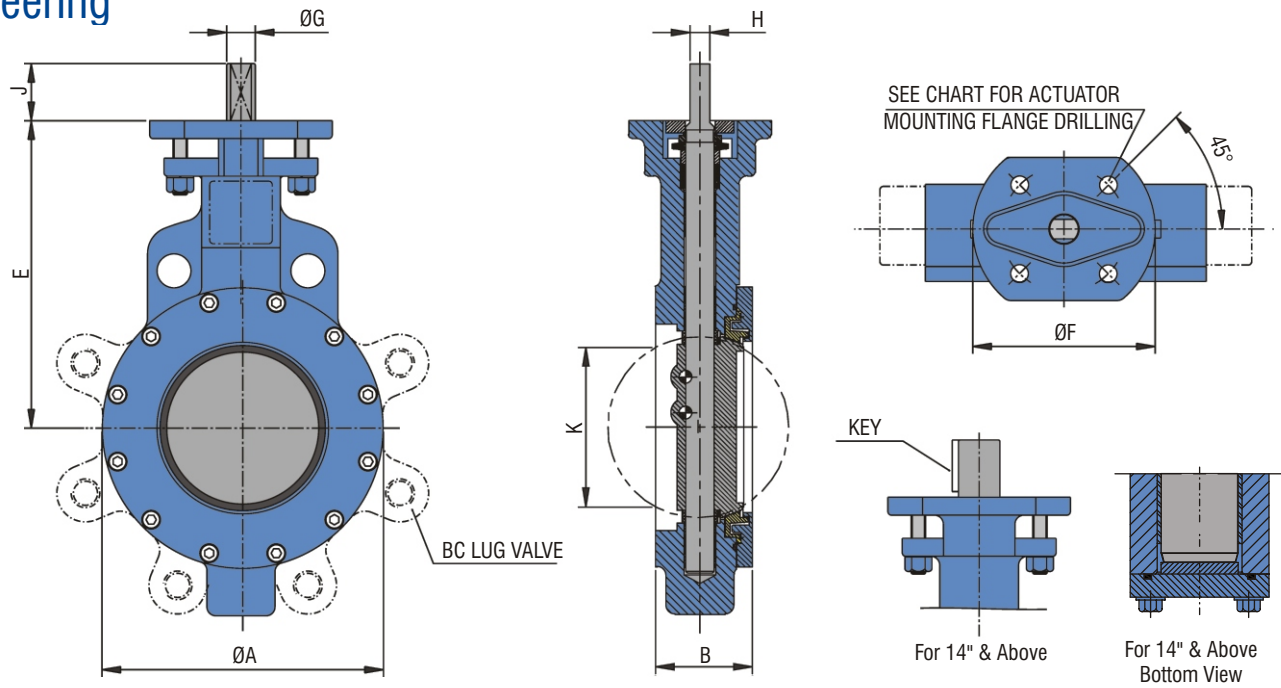

DIMENSIONS (mm)

ASME CLASS 600 (Series 4M/4N)

Valve Size		ØA	* B	E	ØF	Top Flange Drilling			ØG	H	J	Key Size	K	Lug Bolting Data			Weights In Kg.	
Inch	DN					BC	No. of holes	Hole Dia.						BC	No. of holes	Threads UNC/UN-2B	Wafer	Lug
3	80	145	54	178	102	70	4	10	19	13	32	-	66.0	168.3	8	3/4-10	10.5	13.6
4	100	175	64	216	152	125	4	14	22	16	32	-	86.4	215.9	8	7/8-9	18	25
5	125	205	78	235	152	125	4	14	30	22	51	-	114.3	266.7	8	1-8	28	40.5
6	150	236	78	250	152	125	4	14	30	22	51	-	139.7	292.1	12	1-8	35	53.5
8	200	295	102	310	152	125	4	14	35	24	51	-	175.3	349.2	12	1 1/8-8	69	102
10	250	350	117	360	210	165	4	21	50	-	64	12 x 10	218.6	431.8	16	1 1/4-8	126	180
12	300	415	140	400	210	165	4	21	50	-	64	12 x 10	261.8	489.0	20	1 1/4-8	173	246
14	350	450	155	475	300	254	8	17	63.5	-	102	15.88 x 15.88	277.4	527.0	20	1 3/8-8	250	338
16	400	520	178	550	300	254	8	17	76.2	-	102	19.05x19.05	325.0	603.2	20	1 1/2-8	340	495
18	450	590	200	600	350	298	8	21	88.9	-	102	22.23x15.88	374.8	654.0	20	1 5/8-8	492	663
20	500	640	216	652	350	298	8	21	101.6	-	134	25.4x19.05	418.4	723.9	24	1 5/8-8	615	835
24	600	745	232	785	415	356	8	33	120	-	150	32 x 18	506.5	838.2	24	1 7/8-8	975	1310

* Face to Face dimension "B", generally conforming to MSS SP 68 TABLE 1 / API 609 Category B / BS EN 558-1 / ASME B 16.10
All bolt holes 1 1/8" and larger have an 8-Un thread series as per MSS SP 68 & API 609.

TORQUE (Nm)

Maximum Seating & Unseating Torque for ASME Class 600

Valve Size		Soft Seat Design (Teflon / Elastomer)			Fire Safe Seat Design			Metal Seat Design		
		Differential Pressure			Differential Pressure			Differential Pressure		
Inch	DN	Class 300	PN64	Class 600	Class 300	PN64	Class 600	Class 300	PN64	Class 600
3	80	81	91	116	113	130	164	136	156	197
4	100	140	175	232	215	245	305	258	294	366
5	125	238	278	336	340	375	480	408	450	576
6	150	322	395	485	463	520	655	556	624	786
8	200	711	810	1073	888	1020	1243	1066	1224	1492
10	250	1073	1265	1597	1205	1375	1687	1446	1650	2024
12	300	1480	1707	2259	2050	2250	2730	2460	2700	3276
14	350	2632	3026	3685	2660	3192	3724	2954	3397	3988
16	400	3174	3618	4602	3444	3960	4650	3947	4539	5328
18	450	4045	4651	5865	5895	6780	7960	7313	8410	9873
20	500	5506	6332	7984	8717	10024	11757	10402	11962	14043
24	600	7390	8495	10715	13530	15560	18265	16184	18611	21848

Note :- Above torque values are indicative and defined for flow in preferred direction i.e. Seat retainer upstream.
Torque values for flow in non preferred direction i.e. seat retainer downstream, multiply the above values by 1.25

TORQUE (Nm)

Maximum Seating and Unseating Torque for ASME Class 150

Soft Seat Design (Teflon / Elastomer)

Valve Size		Differential Pressure				
Inch	DN	PN3.5	PN7	PN10	PN16	Class 150
2	50	24	26	27	28	29
2.5	65	27	28	29	31	32
3	80	32	33	34	37	40
4	100	43	46	49	53	68
5	125	59	65	70	78	83
6	150	88	95	104	116	124
8	200	148	162	175	199	214
10	250	193	219	244	283	315
12	300	235	285	336	413	465
14	350	389	482	579	735	836
16	400	496	618	744	936	1076
18	450	646	808	966	1224	1409
20	500	862	1087	1296	1663	1897
24	600	1305	1648	2008	2558	2958
26	650	1597	1950	2210	2610	3170
28	700	1755	2150	2490	2830	3360
30	750	2395	2912	3429	4256	4825
32	800	3099	3762	4529	5456	6325
36	900	3865	4762	5659	7094	8081
40	1000	6102	7601	9100	11499	13152
44	1100	7725	8960	10320	13040	14910
48	1200	9950	12450	14770	18806	21420

Maximum Seating and Unseating Torque for ASME Class 300

Soft Seat Design (Teflon / Elastomer)

Valve Size		Differential Pressure				
Inch	DN	PN10	Class 150	PN25	PN40	Class 300
2	50	27	29	32	40	42
2.5	65	29	32	34	42	47
3	80	34	40	44	54	60
4	100	49	68	74	95	108
5	125	88	111	123	161	186
6	150	120	154	175	234	275
8	200	228	300	341	459	545
10	250	338	461	530	731	876
12	300	473	639	729	1002	1189
14	350	724	1058	1258	1807	2194
16	400	879	1270	1492	2181	2645
18	450	1136	1652	1935	2786	3371
20	500	1501	2191	2605	3761	4589
24	600	2047	2979	3485	5101	6158

Fire Safe Seat Design

Valve Size		Differential Pressure				
Inch	DN	PN3.5	PN7	PN10	PN16	Class 150
2	50	52	54	56	59	61
2.5	65	54	57	58	61	63
3	80	69	71	73	77	80
4	100	85	90	94	101	107
5	125	96	104	113	127	137
6	150	161	175	190	213	226
8	200	264	293	315	355	387
10	250	398	443	494	572	628
12	300	593	682	768	896	997
14	350	704	807	905	1080	1190
16	400	812	944	1094	1313	1475
18	450	1034	1289	1571	1980	2285
20	500	1463	1858	2239	2896	3316
24	600	2304	2724	3172	3886	4322

Fire Safe Seat Design

Valve Size		Differential Pressure				
Inch	DN	PN10	Class 150	PN25	PN40	Class 300
2	50	56	61	63	67	70
2.5	65	58	63	66	70	74
3	80	73	80	82	87	92
4	100	94	107	121	144	162
5	125	124	145	157	194	217
6	150	205	247	271	340	389
8	200	337	412	453	576	659
10	250	506	610	669	838	964
12	300	825	1078	1202	1616	1900
14	350	926	1207	1362	1827	2485
16	400	1123	1515	1730	2406	2870
18	450	1727	2552	3021	4385	5359
20	500	2405	3619	4247	6284	7580
24	600	3864	5705	6702	9708	11766

Metal Seat Design

Valve Size		Differential Pressure				
Inch	DN	PN3.5	PN7	PN10	PN16	Class 150
2	50	58	60	63	66	70
2.5	65	68	70	73	76	79
3	80	84	89	91	94	99
4	100	107	113	117	125	134
5	125	119	129	143	159	171
6	150	201	219	236	265	280
8	200	333	369	394	446	482
10	250	490	544	624	707	795
12	300	747	846	964	1118	1254
14	350	880	1021	1132	1347	1485
16	400	1015	1184	1365	1654	1839
18	450	1302	1637	1944	2506	2829
20	500	1814	2304	2789	3638	4149
24	600	2880	3432	3957	4876	5388

Metal Seat Design

Valve Size		Differential Pressure				
Inch	DN	PN10	Class 150	PN25	PN40	Class 300
2	50	63	70	75	79	83
2.5	65	73	79	83	89	91
3	80	91	99	102	108	115
4	100	117	134	150	179	202
5	125	156	180	196	241	269
6	150	255	309	340	426	488
8	200	422	511	573	721	818
10	250	627	760	828	1039	1200
12	300	1040	1334	1511	2012	2394
14	350	1146	1508	1703	2303	2686
16	400	1392	1890	2162	3009	3588
18	450	2159	3217	3745	5435	6648
20	500	3032	4511	5351	7893	9456
24	600	4812	7189	8384	12122	14712

Note :- Above torque values are indicative and defined for flow in preferred direction i.e. Seat retainer upstream.

Torque values for flow in non preferred direction i.e. seat retainer downstream, multiply the above values by 1.25

Feature and Selection

Double Offset Disc Design

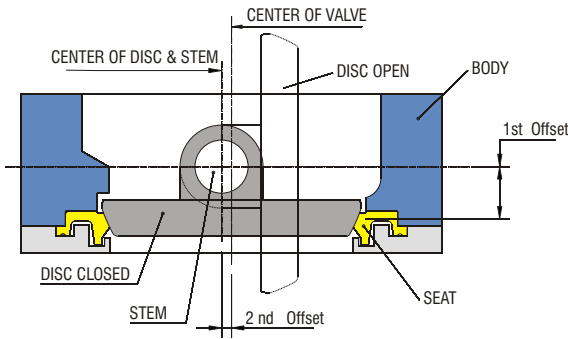

The offset disc produces a cam-like action, pulling the disc from the seat. This action reduces seat wear and eliminates seat deformation when the disc is in the open position. The disc does not contact the seat when the valve is in the open condition; therefore, seat service life is extended and torques are reduced. As the valve closes, the cam-like action converts the rotary motion of the disc to a linear type motion effectively pushing the disc onto the seat.

SEAT PRESSURE / TEMPERATURE

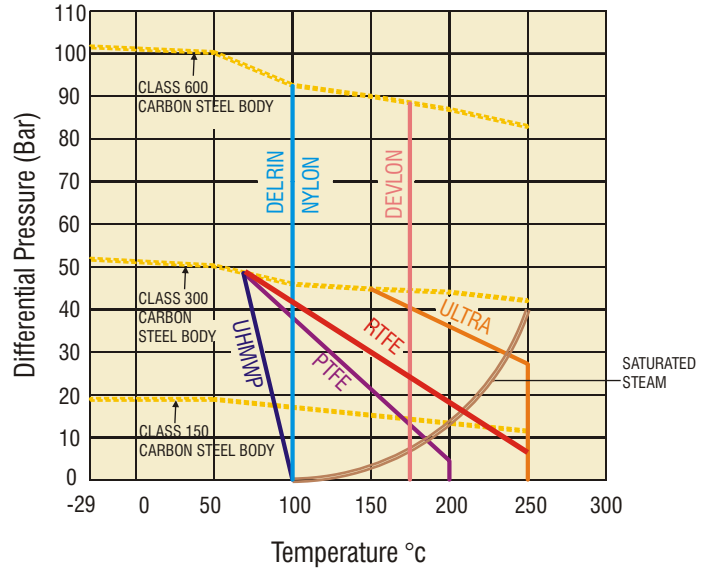

Seat Designs

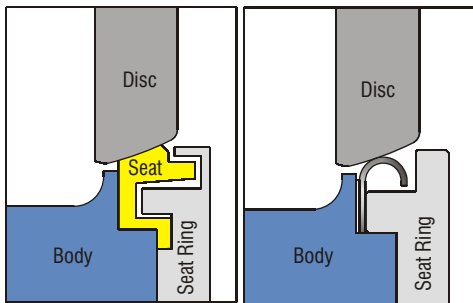

1. Teflon Seat
2" - 24"

2. Metal Seat
2" - 24"

1. **Teflon Seat** : Flexible lip seat design retains its original shape and maintain a seal against the disc regardless of the flow direction

2. **Metal Seat** : Flexible metal seat offers a very high sealing capability with an unusually low leakage rate. The mechanical properties and the shape of the metal seat allows it to flex and maintain constant positive sealing against the disc.

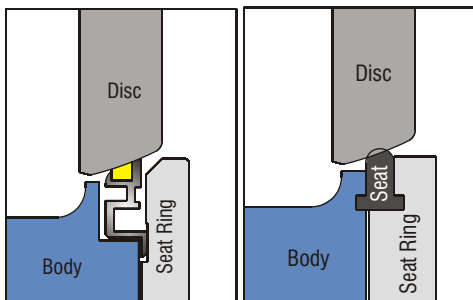

3. Fire Safe Seat
2" - 24"

4. Elastomer Seat
2" - 48"

3. **Fire Safe Seat** : During and after fire, when the resilient material has been partially or completely destroyed, the metal seat ring provides a positive seal by remaining in constant contact with the disc in either direction of media flow.

4. **Elastomer Seat** : The heavy 'T' section seal ring is designed to eliminate the potential extrusion due to high shut-off delta P or high velocity.

Special Applications

ULTRA seat

An engineered fluorocarbon polymer that is rated for 260 °C. Excellent for handling aggressive fluids at high pressures. Ultra is recommended for extended service in hostile environments involving chemical, thermal, and mechanical stress. Ultra has excellent thermal stability and is ideal for steam, hot gases, and a variety of process chemicals where service can be also be subject to pressure cycling.

NACE service

All valves conform to NACE MRO 103 standard. These valves are well suited for oil and gas industry applications requiring resistant materials to sulfide stress cracking.

Steam

Valves are available for saturated steam at 14 Bar rating for series 44 / 45 and 31 Bar for series 47 / 48.

Vacuum

Standard valves are rated for tight shut-off of vacuum to 2×10^{-2} torr.

Oxygen

Valves for critical gaseous oxygen service are specially prepared, cleaned, inspected, assembled and tested to ensure removal of all burrs, sharp edges, dirt, hydrocarbon oil or grease and other contaminants.

CODES AND STANDARDS

General design and manufacturing :- API 609 Category B / MSS-SP-68 / EN 593

Inspection and Testing :- API 598 / MSS-SP-68 / EN 12266-1 / AISI / FCI 70-2

Fire safe testing :- API 607 / ISO 10497 / EN 12266-2

Pressure temperature rating :- ASME B 16.34 // BS EN 12516-1

Materials of Construction

BODY - D.I. ASTM A536 65-45-12 / Carbon Steel, ASTM A 216 WCB / ASTM A352 LCB
Stainless Steel, ASTM A 351 CF8M / CF8

DISC - Stainless Steel, ASTM A 351 CF8M / CF8

STEM - ASTM A 479 SS316 (Class 150 up to 12", soft seat)
ASTM A479 SS 410 (Class 150 / 300)
ASTM A 564 17-4-PH TYPE 630 (Class 600 / 300 / 150)

SEAT - * PTFE / RTFE / ULTRA /UHMWP
Fire Safe Seat (2" - 24")
Metal Seat (SS316, INCONEL)(2" - 24")
EPDM / BUNA-N / SILICONE / VITON / (PN 25 Max.)

STEM PACKING - PTFE Chevron Packing - Standard Valve
Flexible Graphite Rings- Fire Safe & Metal Seat Valve

* For 26" & above consult factory

Other materials are available, please consult factory
for specific application

Sr. No.	DESCRIPTION	
01	BODY	
02	DISC	
03	STEM	
04	SEAT	
05	BODY GASKET (Up to 10")	
06	SEAT RETAINER	
07	SOC. HD. CAP SCREW	
08	DISC SPACER	
09	BEARING	
10	DISC PIN	
11	STEM PACKING	
12	PACKING GLAND	
13	BELLVILLE WASHER	
14	GLAND FOLLOWER	
15	STEM RETAINER CIRCLIP	
16	GLAND FLANGE	
17	STUD	
18	HEX NUT	
19	THRUST BEARING	14" AND ABOVE
20	BOTTOM GASKET	
21	BOTTOM FLANGE	
22	HEX BOLT	

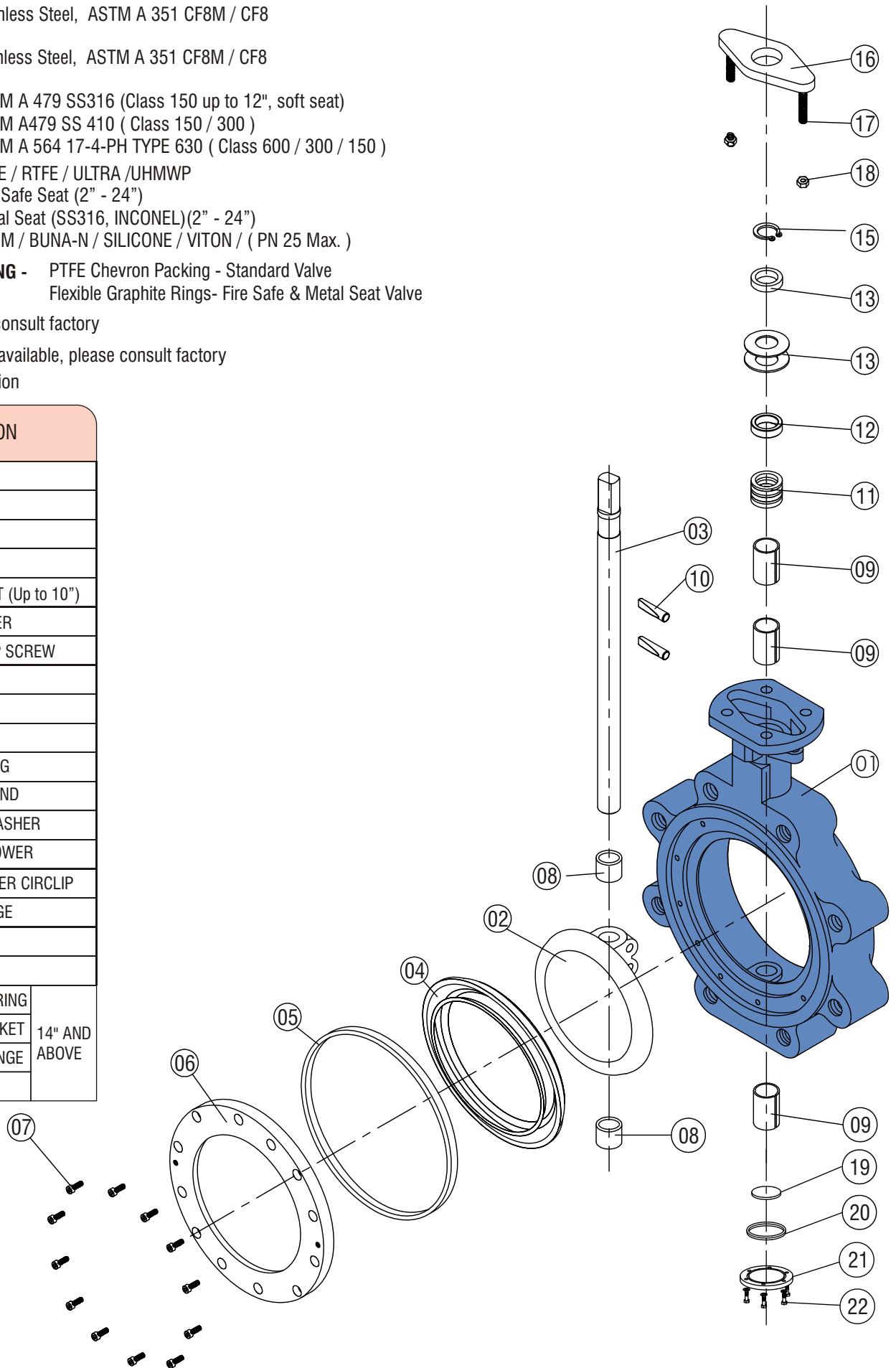

Operators



All valves can be direct mounted with pneumatic actuators or electric actuators and accessories for complete automation options such as fail open/close and positioner controlled. Valves can be mounted with manual overrides.



Valves up to size 48" can be direct mounted with gear operators for manual operation. Gear operators can also be attached with chain-wheel operators for opening or closing valves located on pipelines at high elevations.



Valves upto 6" for class 150 and upto 4" for class 300 can be supplied with lever handles for manual operation. Optional accessories for hand-lever operation can be provided for various flow control requirements. Pad locking can also be provided for preventing unauthorized operation.

How to order DeVal valves

Series		Size		Trim / Other Variables / Special					
□ □		□ □ □		□	□	□	□	□	□
Valve Description	Valve Description	Body	Disc	Stem	Seat	Rating	Operator	Special	
44 : Wafer class 150	020 : 2"	140 : 14"	2 - D.I.	4-CF8M(SS316)	1-SS410	T- PTFE	5 - Class 150	B-BARE	0-NO SPECIAL
45 : Lug class 150	025 : 2.5"	160 : 16"	3- WCB	8- CF8(SS304)	4-SS316	U-ULTRA	6 - Class 300	L - LEVER	REQUIREMENT
47 : Wafer class 300	030 : 3"	180 : 18"	4- CF8M(SS316)		6- 17-4-PH	G-UHMWP	7 - Class 600	G - GEAR	S - SPECIAL
48 : Lug class 300	040 : 4"	200 : 20"	8- CF8(SS304)			R-RTFE			REQUIREMENT
4M : Wafer class 600	050 : 5"	240 : 24"				M-METAL (SS)			AS SPECIFIED
4N : Lug class 600	060 : 6"	260 : 26"				N-METAL (INCONEL)			BY CUSTOMER
	080 : 8"	280 : 28"				F-FIRE SAFE			
	100 : 10"	300 : 30"				E - EPDM			
	120 : 12"	320 : 32"				B - BUNA-N			
		360 : 36"				S - SILICONE			
		400 : 40"				V - VITON			
		440 : 44"							
		480 : 48"							

FOR Example :- To order 300/12" , wafer body valve, Body-CF8M, Disc- CF8M, Stem-SS316, Seat-RTFE, Rating-Class 150, Gear operated, with no special requirements.

4 4 1 2 0 4 4 4 R 5 G 0

All statements, technical information and recommendations in the bulletin are for general use only. DelTech is not responsible for suitability or compatibility of these products in relation to system requirements. Consult DelTech distributors or factory for the specific requirements and material selection for your intended application. DelTech reserves the right to change or modify product design or product without prior notice. DelVal® - Registered trademark of DelTech Controls.

Distributor



DelTech Controls LLC

6068 Highway 73
Geismar, LA 70734
USA

Phone: (225) 744-4326

Fax: (225) 744-4328

Email : sales@deltechcontrols.com

DeVal Flow Controls Pvt. Ltd.

(A division of DelTech Controls LLC, USA)
Office & Works : Gat. No 625/1/2,
Kuruli, Tal. Khed, Pune-Nasik Highway,
Pune 410501, INDIA

Phone : +91-2135-662700

Fax: +91-2135-662727

Email : salesindia@deltechcontrols.com